

## Prostore 500

### 1 Door Digital Freezer, 470lt (-15/-22 °C) - Remote, CO2

ITEM # \_\_\_\_\_

MODEL # \_\_\_\_\_

NAME # \_\_\_\_\_

SIS # \_\_\_\_\_

AIA # \_\_\_\_\_

**691342 (PS04F1FRCO2)**

 1-door prostore Freezer  
 470lt, -22-15°C, AISI 304,  
 remote, CO2 with valve

### Short Form Specification

**Item No.** \_\_\_\_\_

Full door freezer constructed in 304 AISI stainless steel with external bottom panel in anti-corrosive material. Large digital display featuring cabinet temperature display and setting and turbo frost cycle (to rapidly cool warm loads). HACCP-compliant control with alarms and history. Frost Watch Control to defrost only when required with automatic evaporation of defrost water. Optimized airflow provides even temperature distribution on all grids. Fitted with 65 mm-thick polyurethane insulating foam. Self-closing, on-site reversible door features microswitch to switch off the fan when the door is opened and heated door frame. Hidden evaporator to guarantee higher storage capacity and less corrosion problems. Remote refrigeration unit (not included). Specific for CO2 gas, valve is included. Ventilated operation; Interior LED light. For ambient temperatures up to 43 °C.. Supplied with 5 x 520X442mm Rilsan coated grids and n. 5 sets of 2 stainless steel grid runners. Prearranged to fit RS485 port to facilitate connection to a remote computer and integrated HACCP systems.

### Main Features

- Large digital white-digit display with cabinet temperature display and setting and turbo frost cycle (to rapidly cool warm loads).
- IPX5 frontal water protection.
- Connectivity ready for real time access to connected appliances from remote and data monitoring (requires optional accessory).
- Fully compliant HACCP digital control: when temperature exceeds critical limits, acoustic and visual alarms are activated. Up to two months of event are kept in memory.
- Large storage area suitable to contain 520x442 mm grids or shelves to improve net capacity.
- Optimized airflow within the chamber guarantees uniformity of temperature on all grids.
- Hidden evaporator thus guaranteeing higher storage capacity and less corrosion problems.
- Greater storage space: internal structure with numerous charging positions available to host grids, ensuring higher net capacity.
- Adjustable temperature range from -15°C to -22°C.
- Model requires only 1 phase 230V/50Hz supply and can be plugged straight into an existing power socket.
- Tropicalized unit.
- Complies with main international certification bodies and is CE marked.
- Prearranged for remote alarm.
- Low noise level.
- Self closing and on site reversible left/right doors.

**APPROVAL:** \_\_\_\_\_

## Construction

- Stainless steel AISI 304 external panels (galvanized external back).
- Lockable door.
- Inner cell with rounded corners, bottom pressed in only one piece.
- Stainless steel runners and supports easily disassembled.
- Internal components removable without the use of tools to facilitate cleaning operations.
- Pressed stainless steel door handle without joints gathering dust and dirt.
- Easy access to the main components for maintenance.
- Developed and produced in ISO 9001 and ISO 14001 certified factory.
- Solenoid valve included.
- Automatic heated door frame.

## Sustainability



- Frost Watch Control: fully automatic defrost starts only when ice is actually building-up in the evaporator and adapt the defrosting duration to guarantee perfect ice removal while optimizing energy efficiency consumption.
- Insulation thickness: 65 mm of polyurethane injected with ecological foaming gas cyclopentane to ensure effective insulation with minimum energy consumption (thermal conductivity: 0,020 W/m\*K).
- Removable triple-chamber balloon magnetic gasket to improve insulation and reduce energy consumption and ease of cleaning.
- Optical door microswitch to stop the fan once the door is opened, thus minimizing energy waste.
- Interior LED light to save energy and for best internal visibility.

## Included Accessories

- 1 of Pedal opening for cabinets PNC 880324
- 5 of Pair of runners for 470 and 720lt prostore cabinets PNC 880335
- 5 of Rilsan-coated grid 520x442mm for Prostore 470l PNC 880342

## Optional Accessories

- Stainless steel grid (520x442) PNC 880321
- Pedal opening for cabinets PNC 880324
- Kit 4 feet, height 200mm PNC 880325
- Kit of 4 feet-h=67 (marine) PNC 880326
- Kit pair of runners (marine) PNC 880327
- Base frame for 1/1 GN rack for 470lt prostore PNC 880328
- Pair of runners for 470 and 720lt prostore cabinets PNC 880335
- Rilsan-coated grid 520x442mm for Prostore 470l PNC 880342

Front

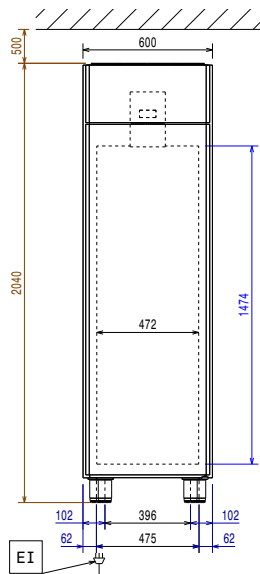

Side

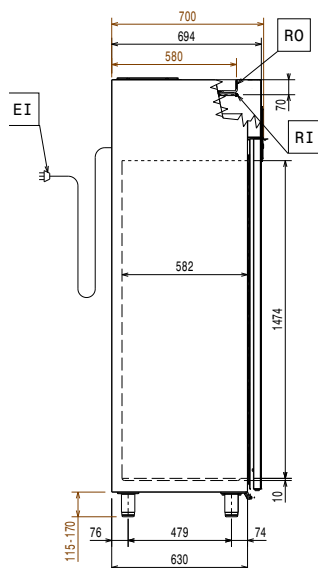

EI = Electrical inlet (power)  
 RI = Refrigerant Inlet  
 RO = Refrigerant Outlet

Top

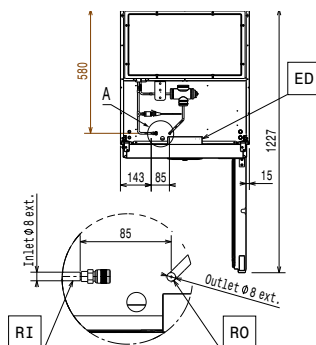

### Electric

Supply voltage:  
 691342 (PS04F1FRCO2) 220-240 V/1 ph/50/60 Hz  
 Electrical power max.: 0.16 kW

### Key Information:

Gross capacity: 470 lt  
 Door hinges: Right Side  
 External dimensions, Width: 600 mm  
 External dimensions, Depth: 700 mm  
 External dimensions, Depth with Doors Open: 1226 mm  
 External dimensions, Height: 2040 mm  
 Number and type of doors: 1 Full  
 Internal Dimensions, Width: 472 mm  
 Internal Dimensions, Depth: 582 mm  
 Internal Dimensions, Height: 1474 mm  
 Height adjustment: 15/40 mm  
 Number and type of grids (included): 5 - 520x442  
 Type of external material: 304 AISI  
 Type of internal material: 304 AISI  
 Number of positions & pitch: 44; 22 mm

### Refrigeration Data

Control type: Digital  
 Condensation temperature: 55 °C  
 Refrigeration type: R744  
 Defrost type: Electric  
 Suggested refrigeration power: 654 W  
 Condition at evaporation temperature: -30 °C  
 Condition at condensation temperature: 55 °C  
 Condition at ambient temperature: 43 °C  
 Connection pipes (remote) - outlet: 8 mm  
 Connection pipes (remote) - inlet: 8 mm

Ref. Power calculated at a linear distance of 15 mt (piping)

\*Note:

### ISO Certificates

ISO Standards: ISO 9001; ISO 14001; ISO 45001; ISO 50001

Prostore 500  
 1 Door Digital Freezer, 470lt (-15/-22 °C) - Remote, CO2

The company reserves the right to make modifications to the products without prior notice. All information correct at time of printing.